



Active Safety

AI Powered
Active Arcing Protection



Higher Yields

Up to 30% More
Energy with Optimizer



2x POWER Battery Ready

5KW AC Output plus
5KW Battery Charge

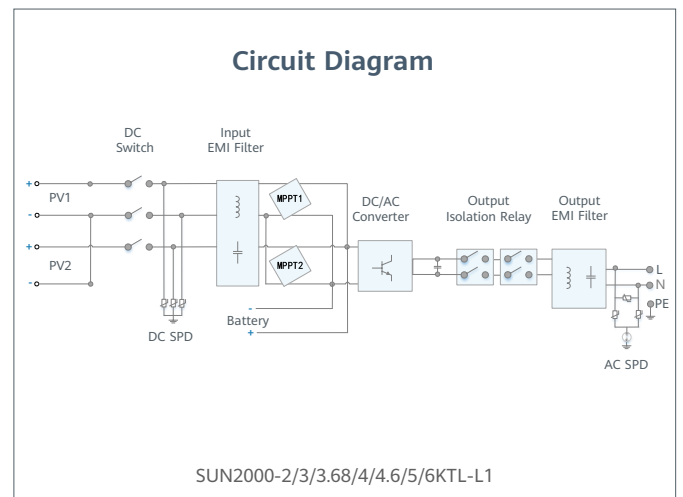
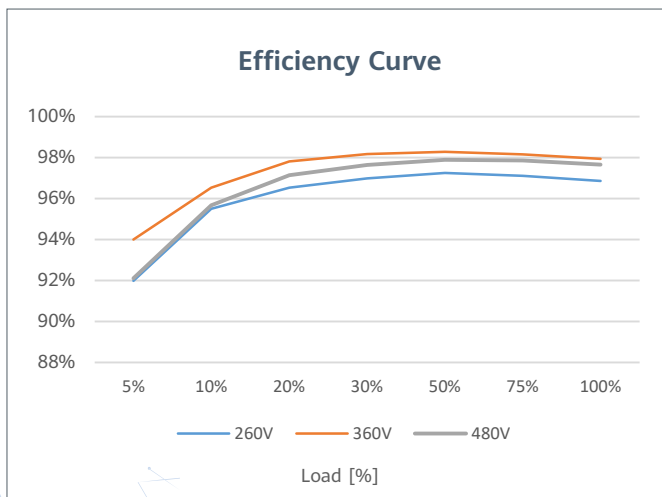

Technical Specification

Technical Specification	SUN2000 -2KTL-L1	SUN2000 -3KTL-L1	SUN2000 -3.68KTL-L1	SUN2000 -4KTL-L1	SUN2000 -4.6KTL-L1	SUN2000 -5KTL-L1	SUN2000 -6KTL-L1 ¹
-------------------------	---------------------	---------------------	------------------------	---------------------	-----------------------	---------------------	----------------------------------

Efficiency

Max. efficiency	98.2 %	98.3 %	98.4 %	98.4 %	98.4 %	98.4 %	98.4 %
European weighted efficiency	96.7 %	97.3 %	97.3 %	97.5 %	97.7 %	97.8 %	97.8 %

Input (PV)

Recommended max. PV power ²	3,000 Wp	4,500 Wp	5,520 Wp	6,000 Wp	6,900 Wp	7,500 Wp	9,000 Wp
Max. input voltage	600 V ³						
Start-up voltage	100 V						
MPPT operating voltage range	90 V – 560 V ³						
Rated input voltage	360 V						
Max. input current per MPPT	12.5 A						
Max. short-circuit current	18 A						
Number of MPP trackers	2						
Max. number of inputs	2						

Input (DC Battery)

Compatible Battery	LG Chem RESU 7H_R / 10H_R						
Operating voltage range	350 ~ 450 Vdc						
Max operating current	10 A @7H_R / 15 A @10H_R						
Max charge power	3,500 W @7H_R / 5,000 W @10H_R						
Max discharge Power @7H_R	2,200 W	3,300 W	3,500 W	3,500 W	3,500 W	3,500 W	3,500 W
Max discharge Power @10H_R	2,200 W	3,300 W	3,680 W	4,400 W	4,600 W	5,000 W	5,000 W
Compatible Battery	HUAWEI PowerMate ESS Battery 5kWh – 30kWh ¹						
Operating voltage range	350 ~ 560 Vdc						
Max operating current	15 A						
Max charge / discharge Power	5,000 W ⁴						

Output

Grid connection	Single phase						
Rated output power	2,000 W	3,000 W	3,680 W	4,000 W	4,600 W	5,000 W ⁵	6,000 W
Max. apparent power	2,200 VA	3,300 VA	3,680 VA	4,400 VA	5,000 VA ⁶	5,500 VA ⁷	6,000 VA
Rated output voltage	220 V / 230 V / 240 V						
Rated AC grid frequency	50 Hz / 60 Hz						
Max. output current	10 A	15 A	16 A	20 A	23 A ⁸	25 A ⁸	27 A
Adjustable power factor	0.8 leading ... 0.8 lagging						
Max. total harmonic distortion	≤ 3 %						
Backup power output	Yes (via Backup Box-5000 ¹)						

Protection & Feature

Anti-Islanding protection	Yes
DC reverse polarity protection	Yes
Insulation monitoring	Yes
DC surge protection	Yes, compatible with TYPE II protection class according to EN/IEC 61643-11
AC surge protection	Yes, compatible with TYPE II protection class according to EN/IEC 61643-11
Residual current monitoring	Yes
AC overcurrent protection	Yes
AC short-circuit protection	Yes
AC overvoltage protection	Yes
Over-heat protection	Yes
Arc fault protection	Yes
Battery reverse charging from grid	Yes

General Data

Operating temperature range	-25 ~ +60 °C (Derating above 45°C @ Rated output power)
Relative operating humidity	0 %RH ~ 100 %RH
Operating altitude	0 ~ 4,000 m (Derating above 2,000 m)
Cooling	Natural convection
Display	LED indicators; integrated WLAN + FusionSolar APP
Communication	RS485, WLAN via inverter built-in WLAN module Ethernet via Smart Dongle-WLAN-FE (Optional); 4G / 3G / 2G via Smart Dongle-4G (Optional)
Weight (incl. mounting bracket)	12.3 kg (27.1 lb)
Dimension (incl. mounting bracket)	365mm * 365mm * 140 mm (14.4 x 14.4 x 5.5 inch)
Degree of protection	IP65

Optimizer Compatibility

DC MBUS compatible optimizer	SUN2000-450W-P
------------------------------	----------------

Standard Compliance (more available upon request)

Safety	EN/IEC 62109-1, EN/IEC 62109-2
Grid connection standards	G98, G99, EN 50549-1, CEI 0-21, VDE-AR-N-4105, AS 4777, C10/11, ABNT, UTE C15-712, RD 1699, TOR D4, IEC61727, IEC62116

¹ Available in 2020 Q3.

² Inverter max input PV power is 10,000 Wp when long strings are designed and fully connected with SUN2000-450W-P power optimizers.

³ The maximum input voltage and operating voltage upper limit will be reduced to 495 V when inverter connects and works with LG battery.

⁴ 2,500 W @ 5kWh HUAWEI ESS battery

⁵ AS4777: 4990W. ⁶ VDE-AR-N 4105: 4600VA / AS4777: 4990VA. ⁷ AS4777: 4990VA. ⁸ AS4777: 21.7A.